

BEMAßTER GRUNDRISS

Zillestraße 7, 10585 Berlin
Eigentumswohnung
3. OG rechts | WE 19

Berlin, 26.10.2023

Ort, Datum

Carsten Waberski

Name

IMMOBILIENVERMESSUNG
Carsten Waberski
Sachtlebenstr. 07
14165 Berlin

Unterschrift



▼ 3. Stock

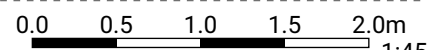
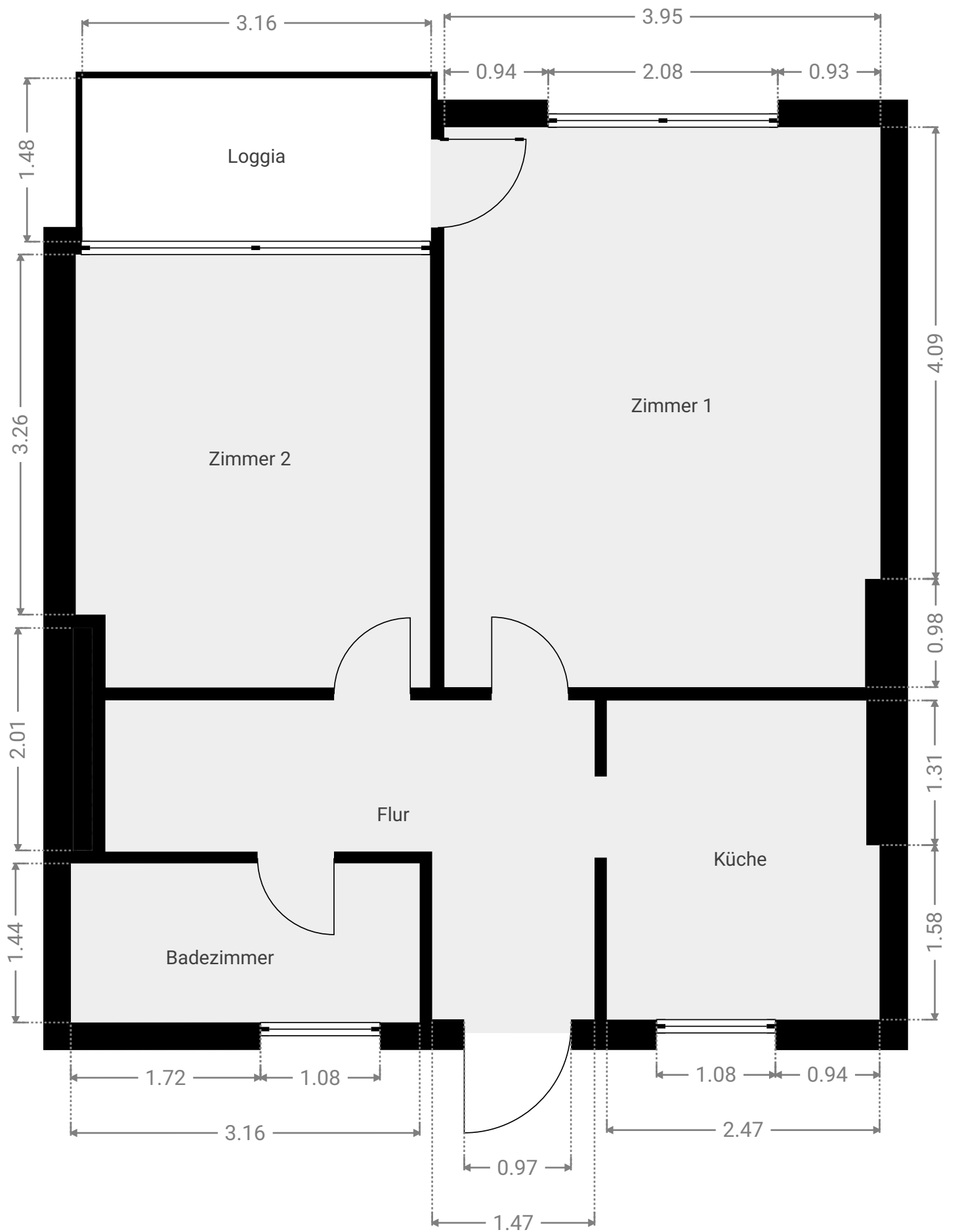

1:45

▼ **Badezimmer**
3. Stock

BREITE: 3.16 m • LÄNGE: 1.44 m
BEREICH: 4.55 m² • UMFANG: 9.20 m

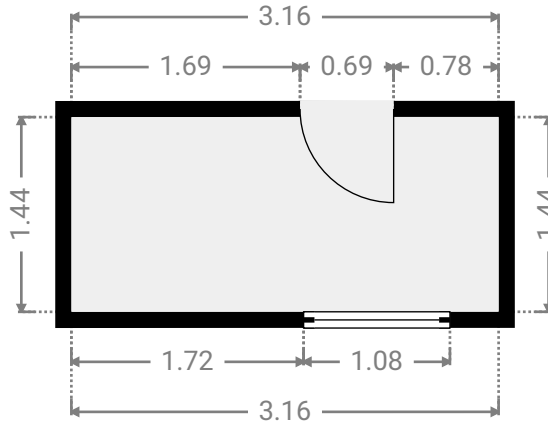
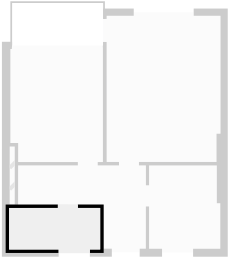

▼ **Flur**
3. Stock

BREITE: 4.43 m • LÄNGE: 2.89 m
BEREICH: 8.31 m² • UMFANG: 14.64 m

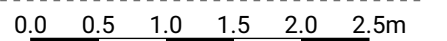
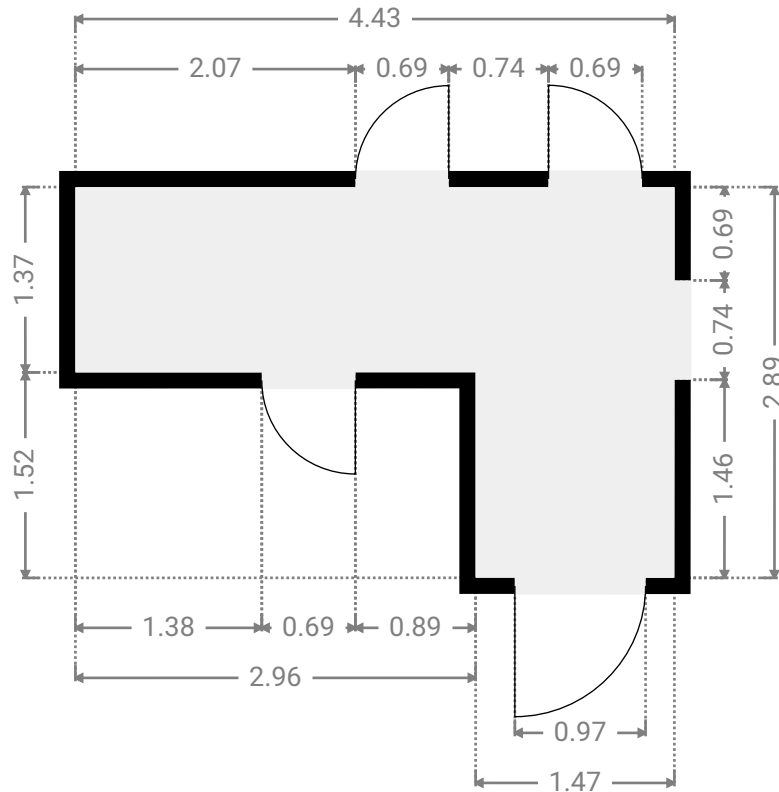
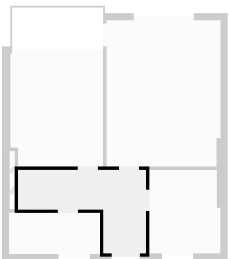

1:56

▼ **Küche**
3. Stock

BREITE: 2.47 m • LÄNGE: 2.89 m
BEREICH: 6.98 m² • UMFANG: 10.72 m

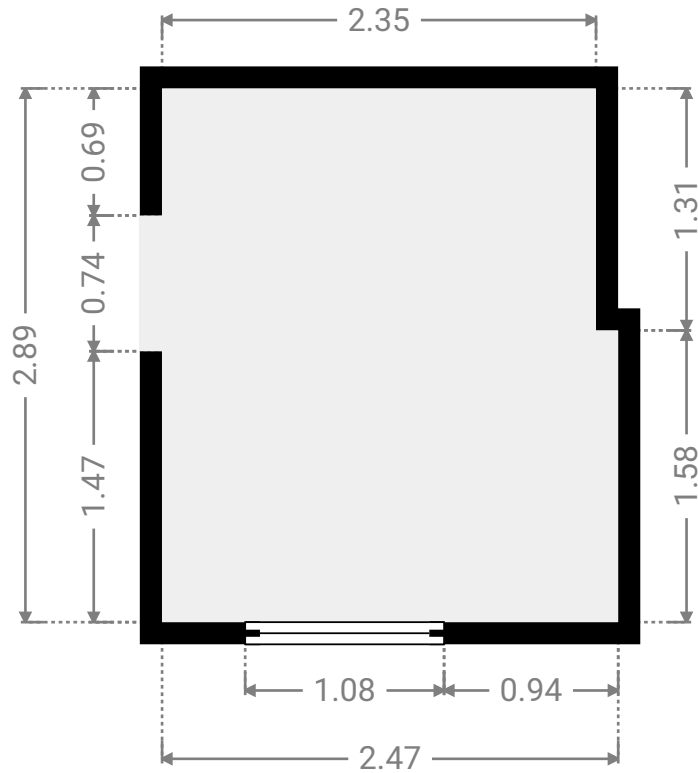
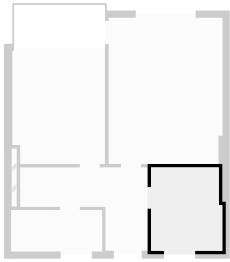

▼ **Loggia**
3. Stock

BREITE: 3.16 m • LÄNGE: 1.48 m
BEREICH: 4.68 m² • UMFANG: 9.28 m

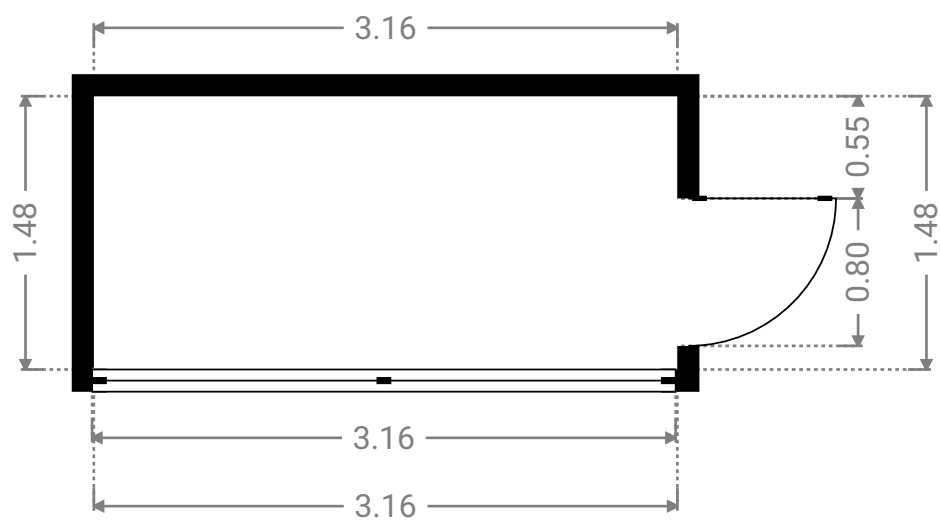
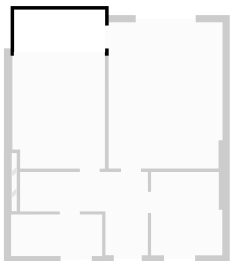

▼ **Zimmer 1**
3. Stock

BREITE: 3.95 m · LÄNGE: 5.07 m
BEREICH: 19.89 m² · UMFANG: 18.04 m

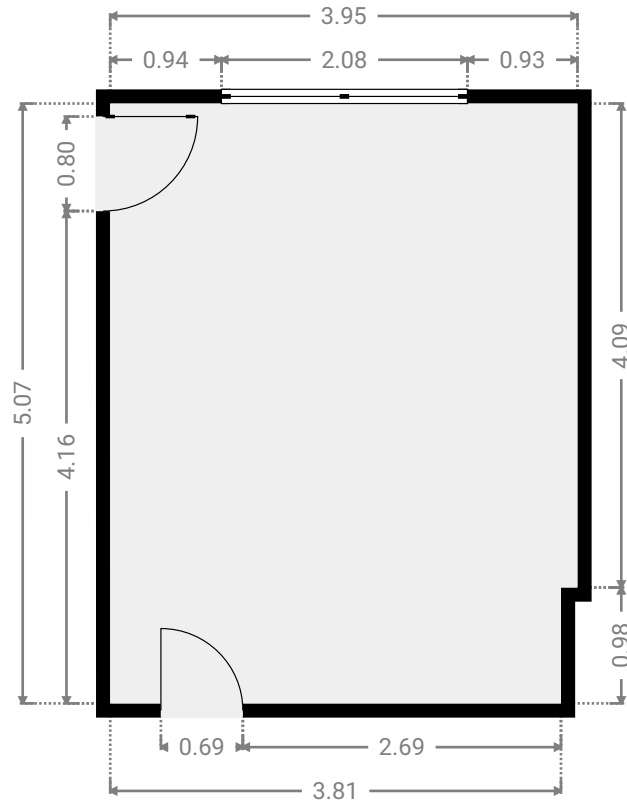
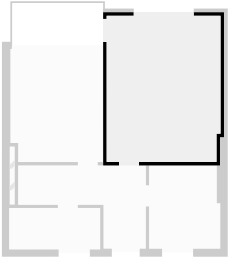

▼ **Zimmer 2**
3. Stock

BREITE: 3.21 m · LÄNGE: 3.92 m
BEREICH: 12.41 m² · UMFANG: 14.26 m

